

JVC | Instruction Book

DIRECT DRIVE
FULLY AUTOMATIC TURNTABLE
JL-F45



A GUIDE TO THIS INSTRUCTION BOOK

Thank you for buying JVC's JL-F45 Direct-Drive fully automatic stereo turntable. You are now the owner of a sophisticated turntable of precise and sturdy fully-automatic mechanism driven by the direct-drive phono motor. Many advanced features of this turntable will be correctly and efficiently utilized only when you read this instruction book, understand it and operate the turntable correctly. Before the setting-up, you should read the important precautions in this manual. Wishing you happy and successful listening.

CONTENTS

IMPORTANT	1
PREPARATION	2
ADJUSTMENT	2
OPERATION (HOW TO USE)	6
CARTRIDGE MOUNTING	8
STYLUS REPLACEMENT	8
TROUBLESHOOTING	8
SPECIFICATIONS	9

IMPORTANT

WARNING

TO PREVENT FIRE OR SHOCK HAZARD,
DO NOT EXPOSE THIS APPARATUS TO
RAIN OR MOISTURE.

CAUTION

TO PREVENT ELECTRICAL SHOCK, DO
NOT REMOVE SCREWS, COVER OR CABI-
NET. NO USER-SERVICEABLE PARTS
INSIDE. REFER SERVICING TO QUALI-
FIED SERVICE PERSONNEL.

In the United Kingdom (U.K.)

THE MAINS VOLTAGE OF THIS APPA-
RATUS HAS BEEN FIXED TO 240V~,
50Hz.

IMPORTANT

The wires in this mains lead are coloured in
accordance with the following code:

BLUE: NEUTRAL
BROWN: LIVE

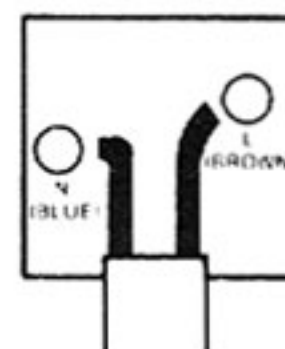

As the colours of the wires in the mains
lead of this apparatus may not correspond
with the coloured markings identifying the
terminals in your plug, proceed as follows.
'The wire which is coloured blue must be
connected to the terminal which is marked
with the letter N or coloured blue or
black.'

'The wire which is coloured brown must be
connected to the terminal which is marked
with the letter L or coloured brown or red.'

PREPARATION

Until you finish all the preparatory processes, do not plug the power cord into the wall supply outlet.

■ Unpacking

Unpack the turntable as shown in Fig. 1.

Note: Do not remove the stylus protector cover until you adjust the "Tracking Force".

■ Setting Up

a) Platter setting up

1. Take out the separately packed platter and the platter mat at the bottom of the shipping carton.
2. Taking care that the motor shaft fits the hole in the platter, slowly place the platter onto the motor shaft.
3. Don't try to force the platter onto the motor shaft; it should fit smoothly.
4. Place the platter mat on the platter.

b) Main weight mounting

Mount the main weight onto the weight shaft (slide pipe) with the tracking force dial end toward the tonearm support base and slide it as close to the tonearm base as possible as shown in Fig. 1.

c) EP adaptor mounting

Place the EP Adaptor onto the EP Adaptor Boss.

d) Cartridge mounting

Remove the headshell from the tonearm by loosening the connector nut. Connect four lead wires on whatever cartridge you have selected. Cartridge lead wires are usually color-coded as illustrated in Fig. 18. Mount the cartridge to the headshell by two screws and nuts loosely as shown for easier overhang adjustment. (Refer to page 4)

e) Headshell mounting

Insert the cartridge-equipped headshell into the connector nut at the end of the tonearm. Push it slightly in the direction of the straight arrow and tighten it firmly by turning the connector nut. Do not remove the stylus protector cover during this procedure.

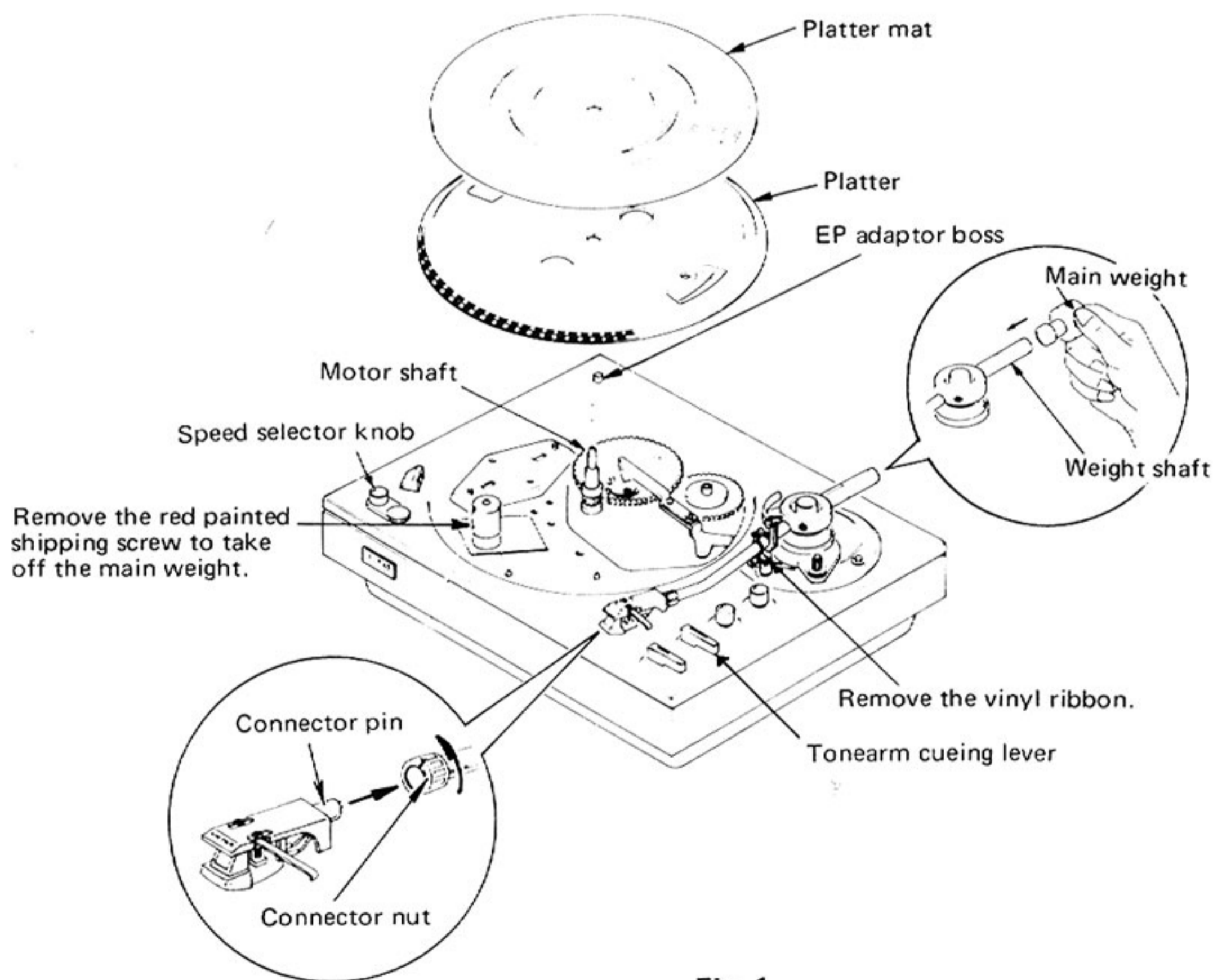

Fig. 1

ADJUSTMENT

The following four adjustments are recommended to be made when you changed a cartridge or a headshell. Otherwise, no adjustment is required. The headshell attached to your JL-F45 or the spare is recommended for use with this turntable.

■ Tracking force adjustment

1. Set the speed selector knob to "STOP" position.
2. Confirm the tonearm cueing lever to be at "DOWN" position.
3. Place an unwarped LP record on the platter.

4. Set the anti-skating knob to "0" dial to make the "Zero Balance" (or equilibrium) adjustment of the tonearm; unless otherwise, tracking force adjustment will not be correctly made as the tonearm tends to skate toward the center of the platter during the adjustment. See Fig. 2.

5. Remove the stylus protector cover as in Fig. 3.

6. Release the tonearm clamp as in Fig. 4.

7. Move the tonearm by hand from the tonearm rest to about 2cm from the outer edge of the LP record. (Fig. 5)

8. Slide the main weight to the approximate center of the slide pipe as shown in Fig. 6. Turn the slide pipe (↺) so as to reach the rubber unit. Turn the slide pipe to the right (↻) as shown in Fig. 6 so as to have the cartridge end of the tonearm float upward slowly when it is freed.

Note: Main weight portion is consisted of the main weight, the slide pipe and the tracking force dial with numbers. Do not move the main weight from the approximate center of the slide pipe until you have adjusted the tracking force. Turning the slide pipe makes the simultaneous turn of the tracking force dial, but turning only of the tracking force dial does not cause the slide pipe turn.

9. Now, turn the slide pipe slowly to the left (↺) as shown in Fig. 7 so as to have the cartridge end of the tonearm float gradually downward. Stop turning it when the stylus tip is nearly touching the surface of the record. The tonearm has now been almost horizontal, which is called "zero balance" and the tracking force is "0"(zero) gram.

Note: When you turn the slide pipe, take care not to damage the stylus tip by its accidental touch to the record surface.

10. Move the tonearm to the rest and clamp it as shown in Fig. 8.

11. Holding the slide pipe firmly at the adjusted position, turn the tracking force dial only so as its "0" mark to line with the index line, as in Fig. 9.

12. Turn the slide pipe to the left (↺) as shown in Fig. 10, which automatically turns the tracking force dial simultaneously, and the number on the tracking force dial at the index shows the tracking force in grams. If the optimum tracking force of your cartridge is 2.0 grams, turn the slide pipe so as the "2" mark on the tracking force dial to line with the index line gradually from "0", "0.5", "1"

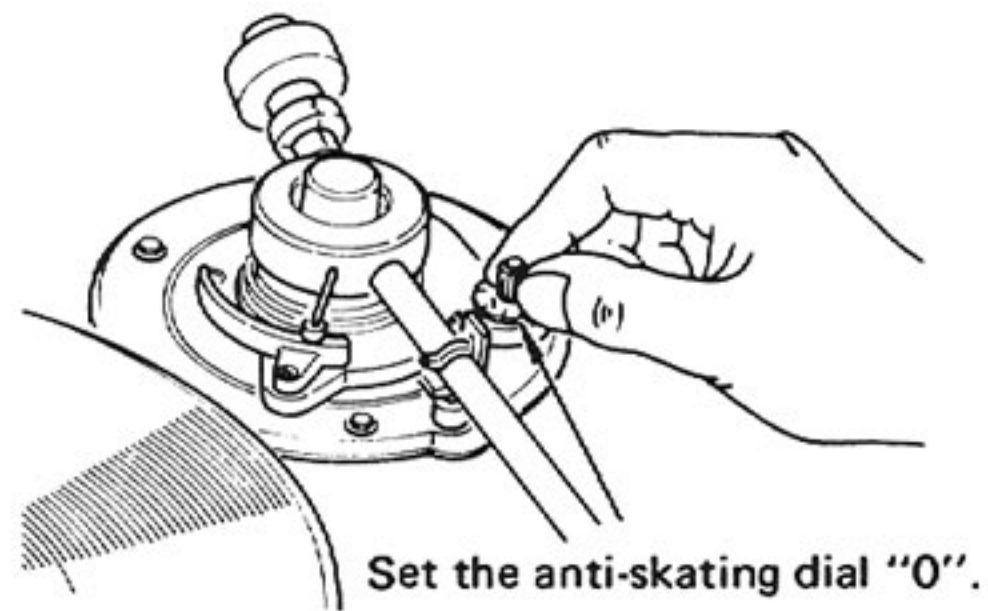

Set the anti-skating dial "0".

Fig. 2

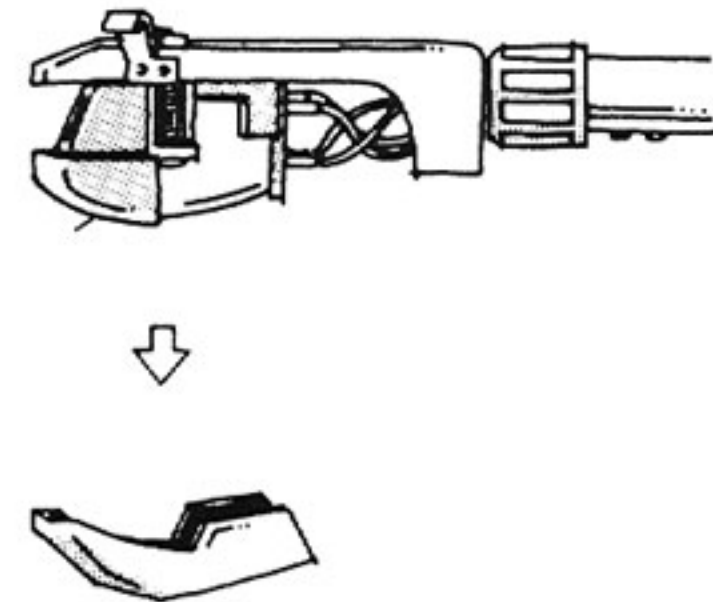

Fig. 3

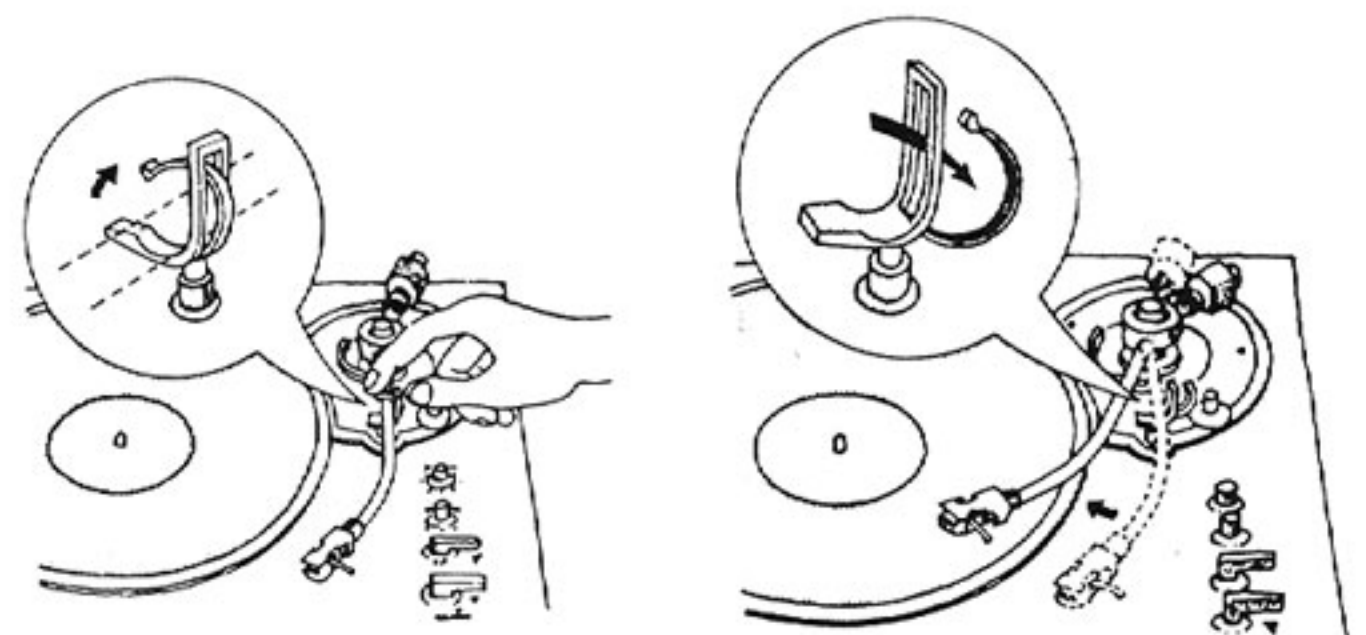

Fig. 4

Fig. 5

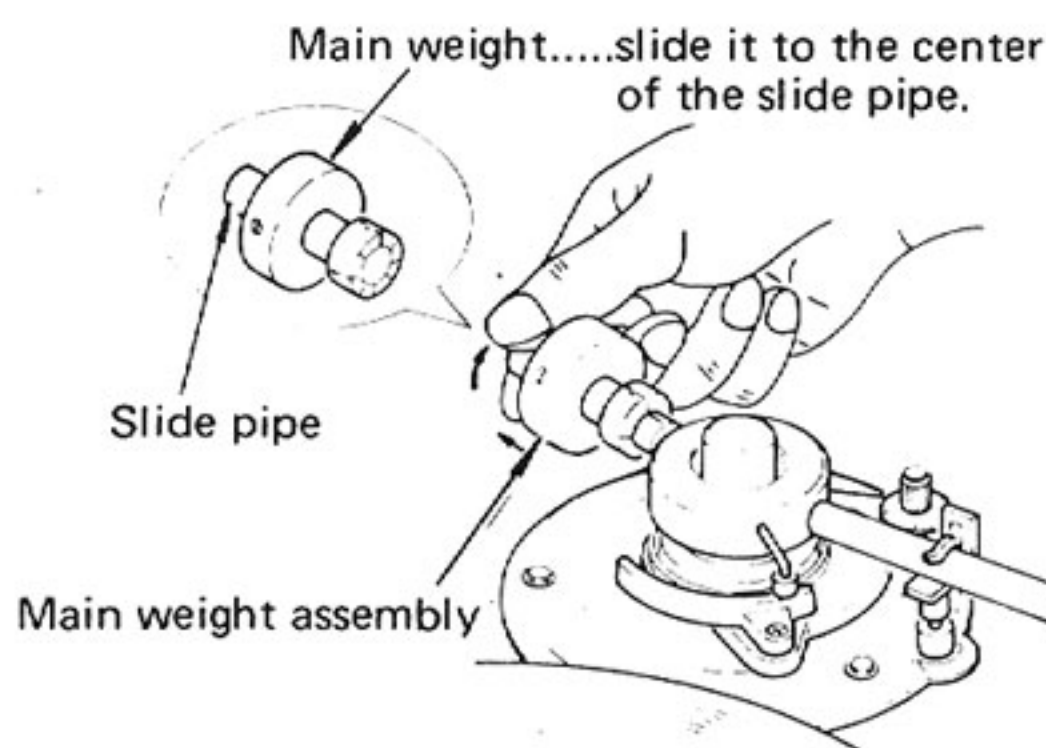
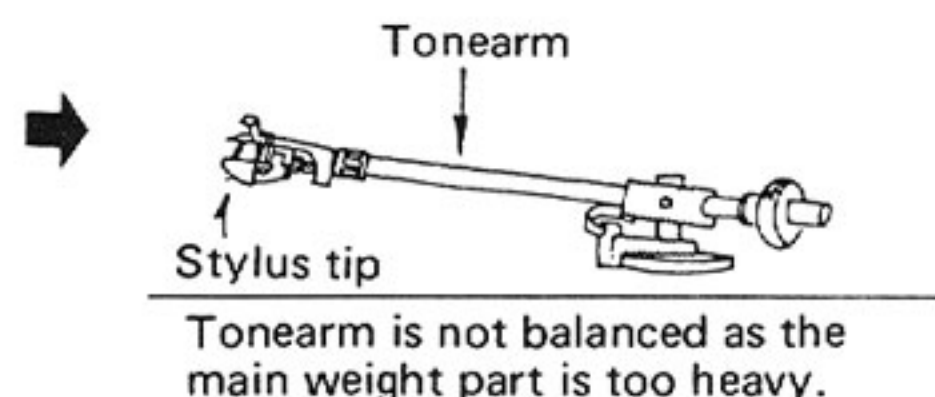

Fig. 6



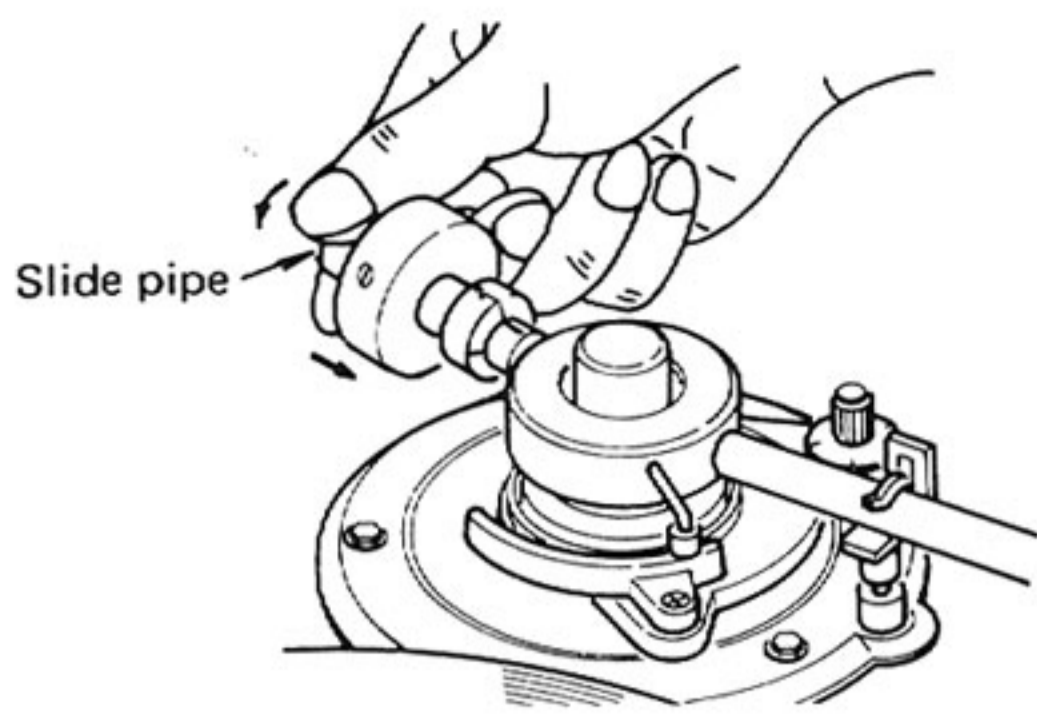

Fig. 7

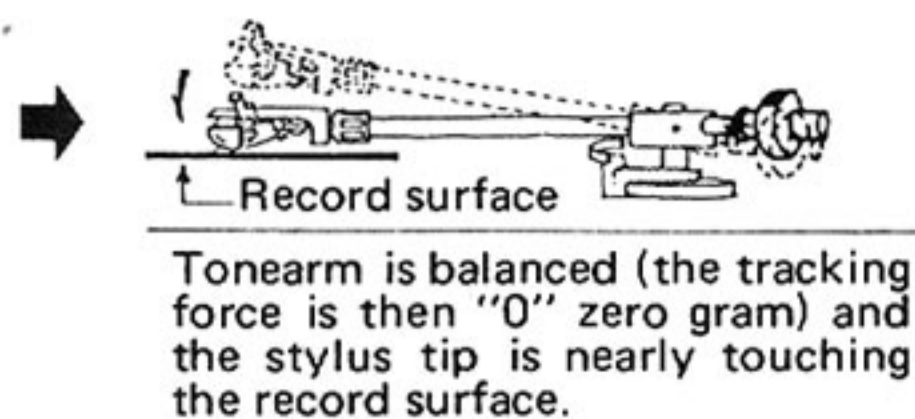

Fig. 8

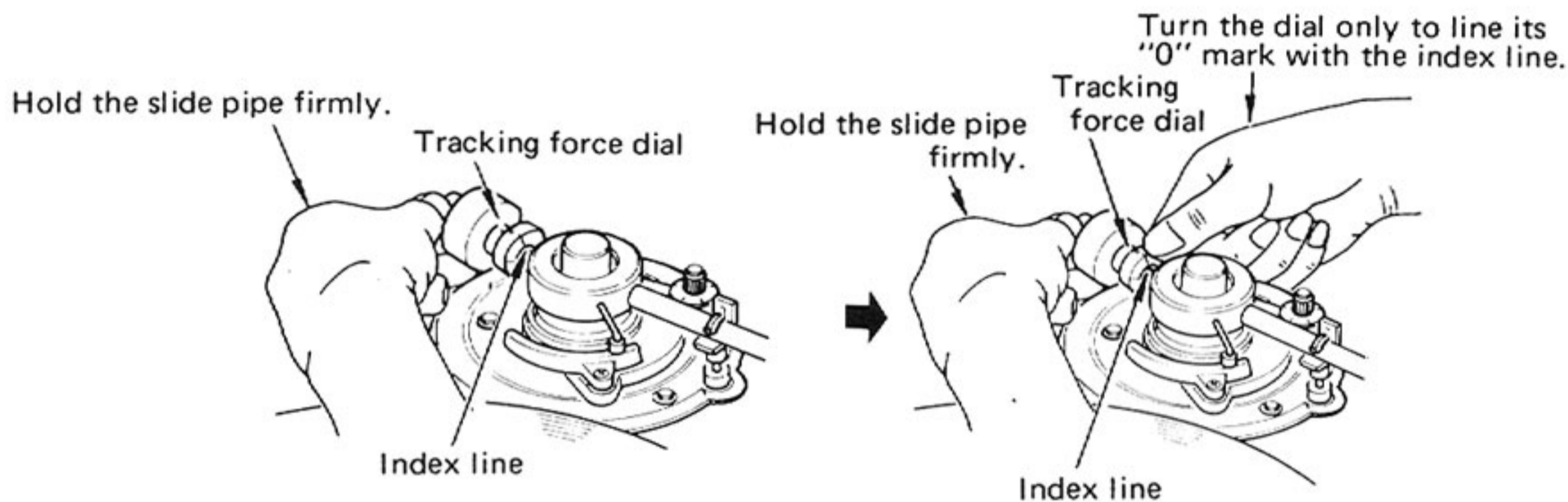

Fig. 9

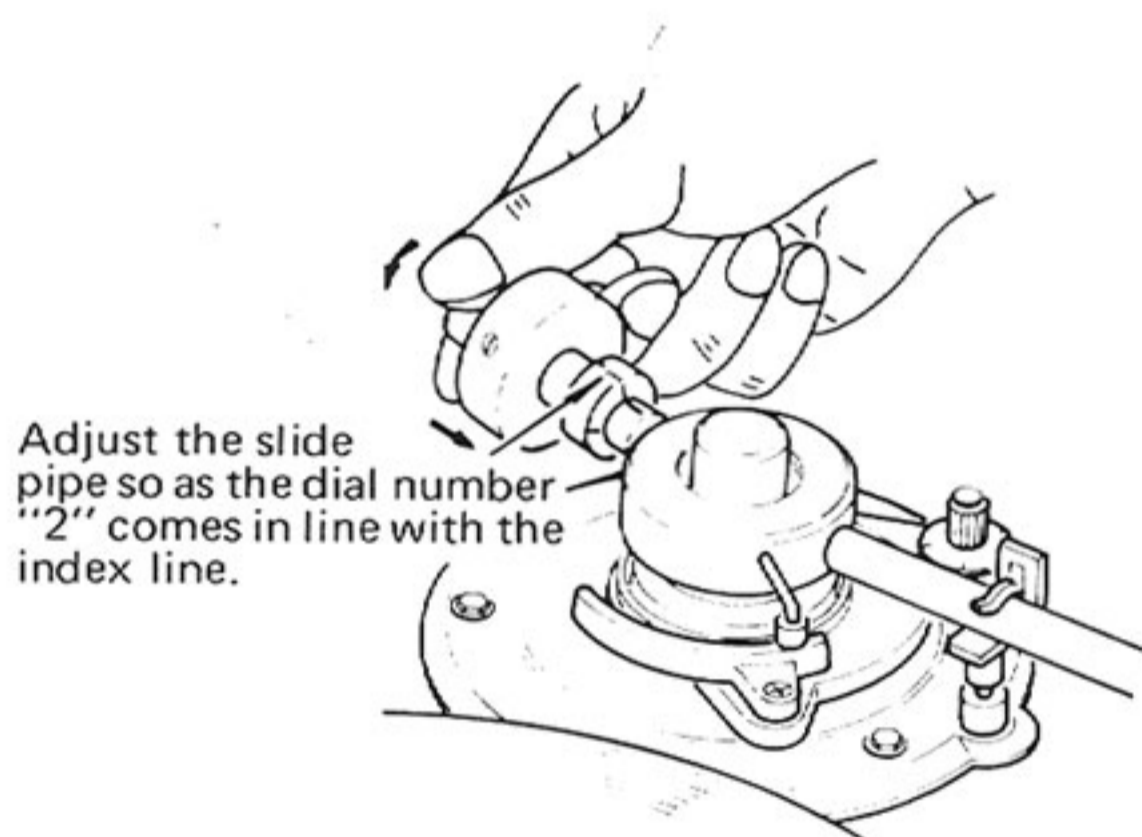

Fig. 10

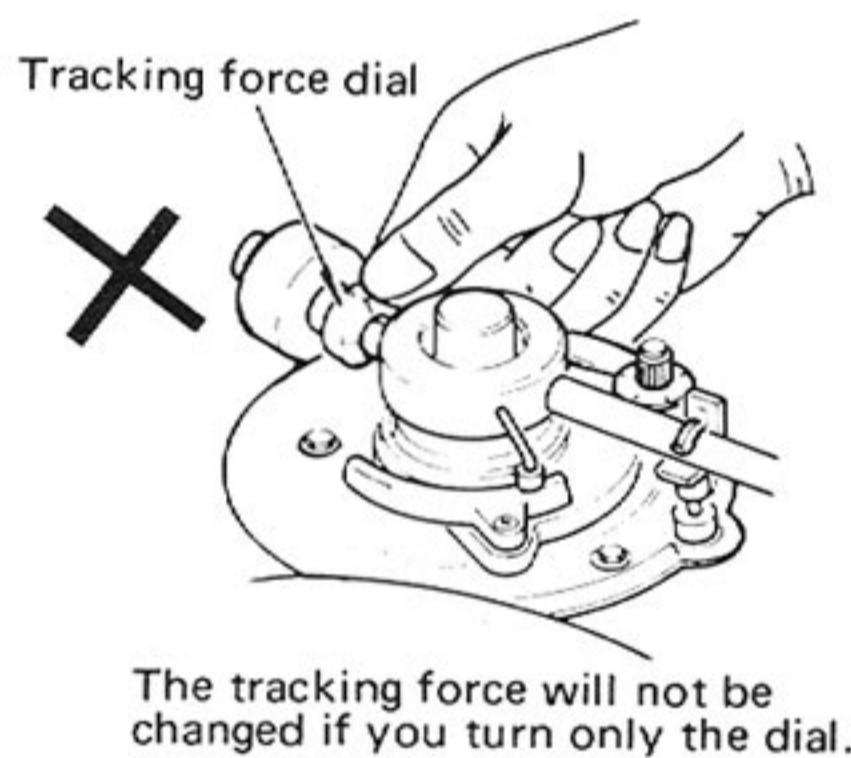

Fig. 11

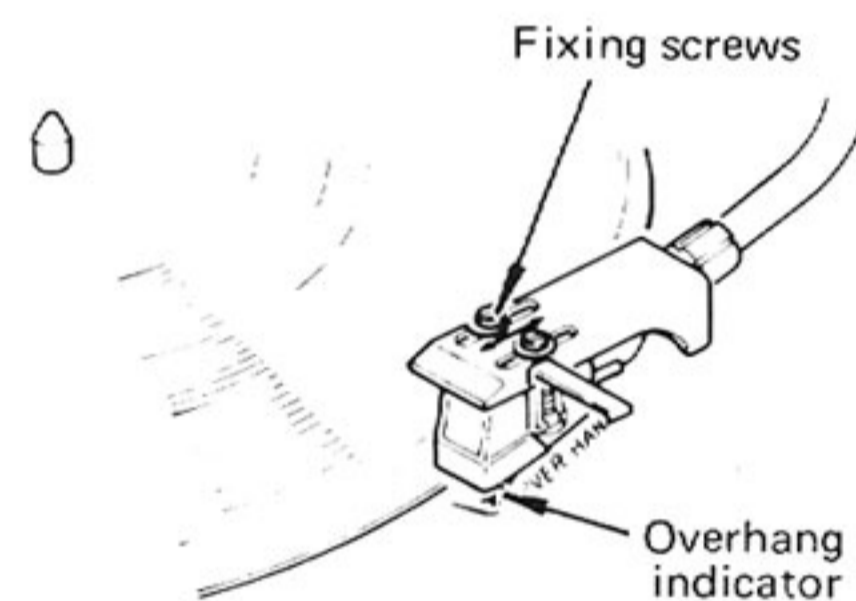

Fig. 12

■ Overhang adjustment (Stylus tip position adjustment)

The tonearm overhang is the distance between the stylus tip and the center spindle. To make the overhang adjustment easier, your JL-F45 has the overhang adjustment point on the motor board. To adjust the overhang, loosen the fixing screws and slide the cartridge to make the stylus tip come just over the overhang indicator and fix the cartridge firmly on the headshell by the screws and nuts. (See Fig. 12)

■ Tonearm elevator height adjustment

The optimum clearance between the stylus tip and the record surface is about 6mm when the tonearm is supported by the tonearm elevator (the cueing lever is set at "UP" position). Turning the adjusting screws as shown in Fig. 13 clockwise lowers the height of the tonearm elevator and counter-clockwise increases it.

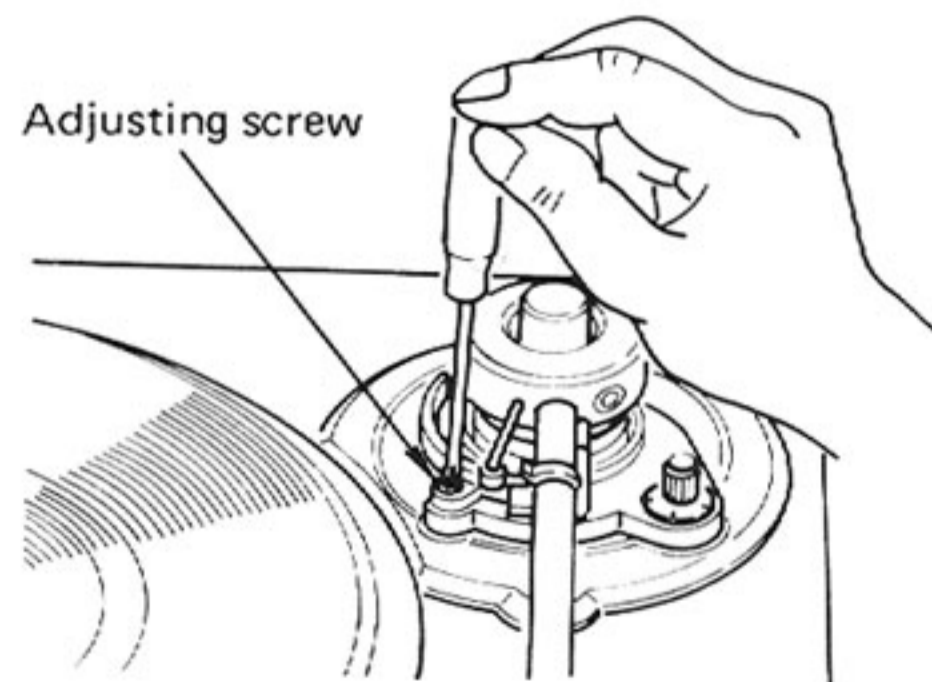

Fig. 13

■ Stylus angle adjustment

When the headshell is locked into the end of the tonearm, the stylus in some cartridges may still not be tangential (90°) to the platter. If such is the case, loosen the locking screws on the lower side of the tonearm using a small screw driver (as in Fig. 14) and adjust the stylus at the right angle (90°) to the platter.

Eye-measurement is sufficient. Be sure to re-tighten the screws when the adjustment is completed.

■ Stylus lead-in adjustment

Your JL-F45 was shipped from the JVC factory with its stylus lead-in adjustment made properly. However, if the stylus lead-in position is changed due to cartridge or headshell changes, etc., adjust it as in the following.

1. Place a 30cm record on the platter.
2. Set the record size select knob to "30" and operate the turntable in automatic play.
3. Confirm if the stylus lead-in position is about 3 to 4mm inward from the outermost edge of the record disc.
4. If the lead-in position is not in the proper range, turn the adjustor screw with a screw driver clockwise to increase the distance between the lead-in position and the outermost edge, and counter-clockwise to decrease the distance. Thus find the proper lead-in position about 3 to 4mm inward from the disc edge.

Note:

The JL-F45 for U.S.A. and Canada has a cap covering the hole for the adjusting screw. Remove the cap at the adjustment.

■ Anti-skating adjustment

Turn the dial of the anti-skating knob to the tracking force of the cartridge you mounted on your JL-F45 as in Fig. 16, with the number of the dial corresponding to the tracking force.

■ Fine pitch adjustment

1. Connect the AC plug to the wall AC output.
2. Set the tonearm cueing lever to "UP" position.
3. Select either of the speeds "33" or "45" and the platter rotates.
4. See the proper strobe pattern 50 or 60Hz of the speed of the turntable you selected. (See Fig. 17.)
5. When you see the strobe pattern flow from right to left, the platter is running at a faster speed than the intended one. Turn the fine pitch control knob to the direction of "S" which stands for "SLOW".
6. When you see the strobe pattern flow from left to right, the platter is running at a slower speed than the intended one. Turn the fine pitch control knob to the direction of "F" which stands for "FAST".
7. When you see the strobe pattern appear standing still, the platter is running at a correct speed as the intended one.

As your JL-F45 is designed to keep the correct speeds all the time once fine pitch adjustment has been done in spite of fluctuations of AC mains voltage and frequency (normally $\pm 0.4\%$ on average) which may cause slight changes of the strobe patterns due to the neon lamp lighting, you need not re-adjust the fine pitch control.

When you completed the fine pitch adjustment for 45r.p.m., remove the attached strobe plate from the platter before playing record.

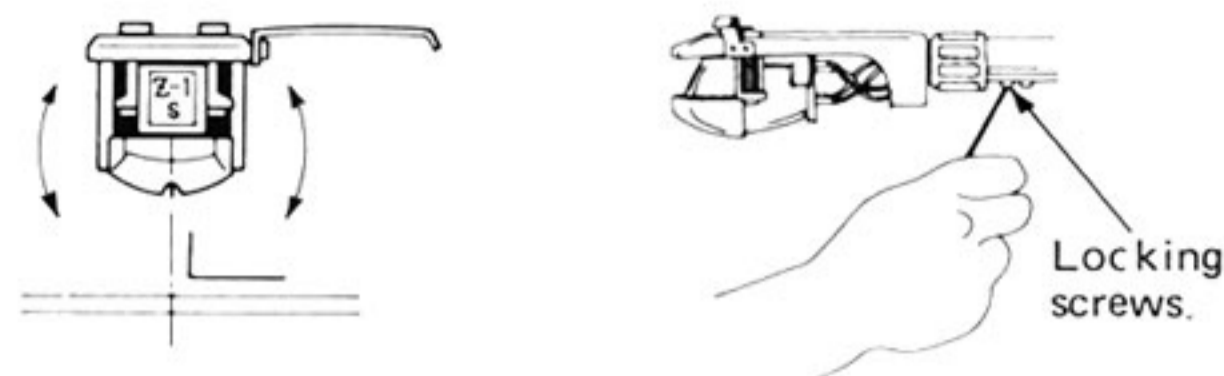

Fig. 14

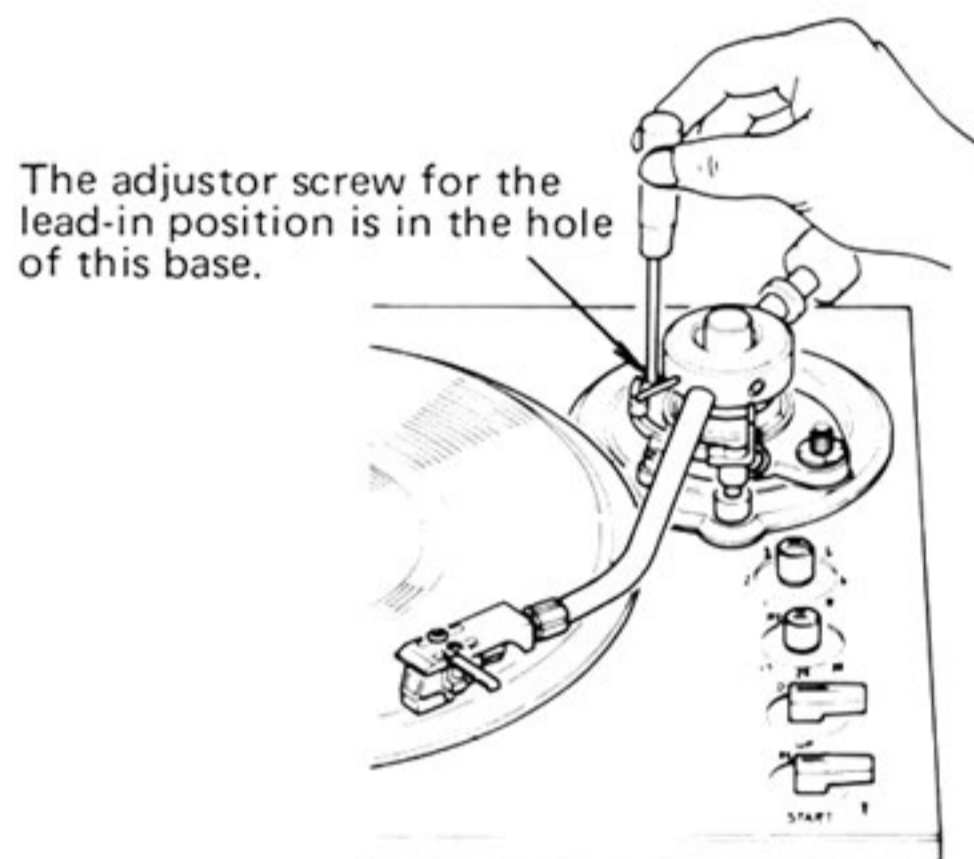

Fig. 15



Fig. 16

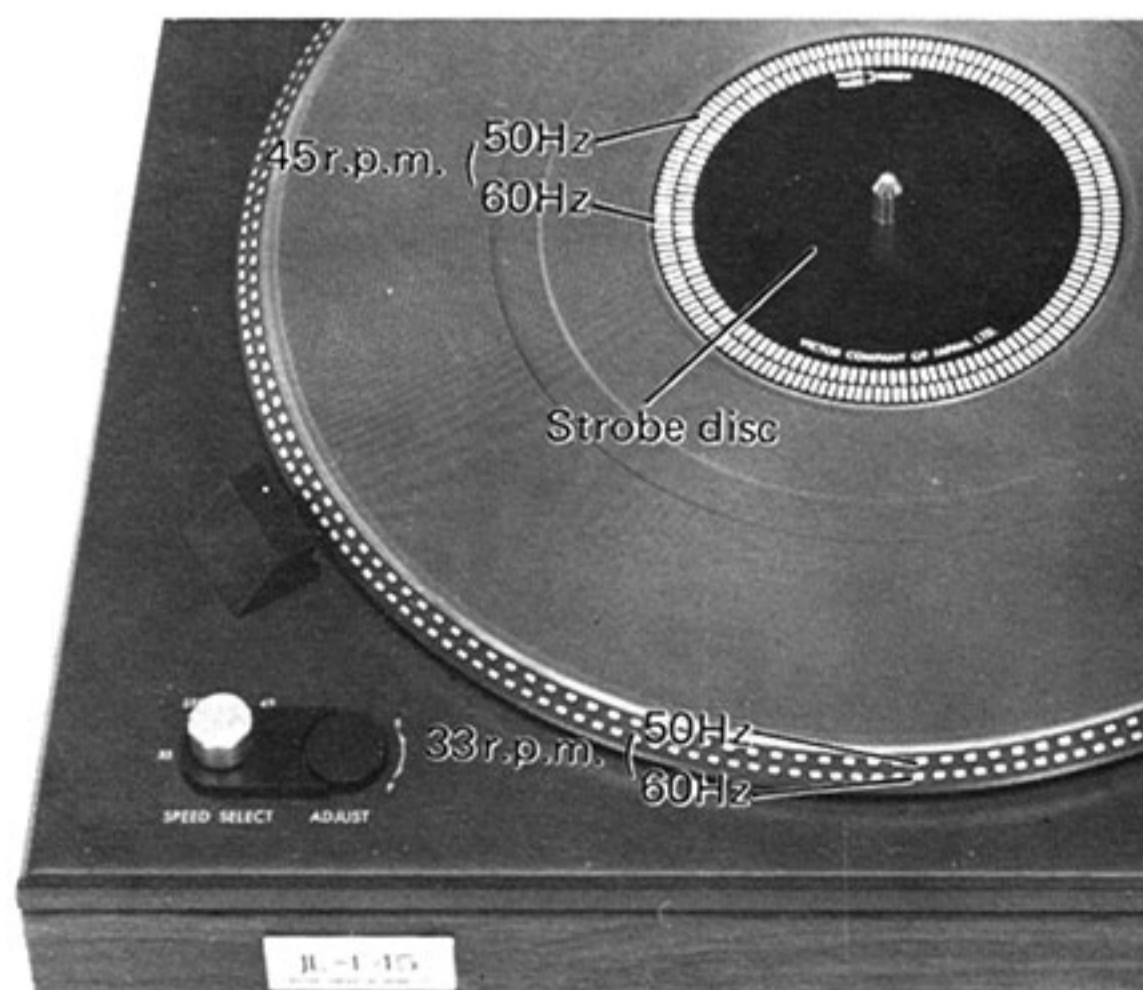

Fig. 17

OPERATION (HOW TO USE)

■ Description of the turntable parts and functions

① Speed select knob

Select a proper position of the speed select knob in accordance to the r.p.m. of the record:
33-1/3 r.p.m. record (LP)....."33"
45 r.p.m. record (EP) "45"
To keep the platter stopped
..... "STOP"

Note: When the knob is set at "STOP" position, the platter will not rotate even though the power is on and the neon lamp is lighted.

② Fine pitch control knob

Adjust this knob by turning it so that the stroboscopic pattern on the platter edge may appear standing still.
(Refer to "Fine pitch adjustment")

③ Neon lamp

This lightens the strobe pattern on the rim of the platter.

④ EP Adaptor

Place this adaptor onto the center spindle when you play a record with the bigger center hole such as a doughnut record.

Center Spindle

⑤ Anti-skating knob

This device cancels the centripetal force that pulls the tonearm to the center of the platter. This prevents skating of the stylus tip towards the center of the platter and the improper force of the stylus tip onto the inner side of the record groove.

⑧ Start and reject lever

When you start playing the record, pull the lever gently to the arrow of "START" and release it. The lever returns to its original position and the tonearm moves automatically to the position of the first groove of the record pre-selected and gently lowers itself to play the record.

When you stop playing the record, push the lever gently to the arrow of "REJECT" and release it. The lever returns to its original position and the tonearm lifts itself up, returns automatically to its rest and the platter quietly stops rotating.

In case of the "REPEAT" knob being set for more than "2" times repeats, the tonearm trips more than twice and the platter quietly stops rotating.

⑥ Repeat knob

Set the knob to a position of the number of repetition you want to listen to the record before playing.

⑦ Record size select knob

Set the knob to the corresponding position to the size of the record before you play it.

30cm diameter record..... "30"(12")
25cm diameter record..... "25"(10")
17cm diameter record..... "17"(7")

⑨ Tonearm cueing lever

This is used when you want the tonearm gently lifted up or lowered down. When you pull it to "UP" position, the tonearm will be lifted up, and when you push it to "DOWN" position, it will be lowered down gently on the record surface.

■ Operation

Note: Confirm before operation that the tracking force adjustment has been completed.

1. Automatic play

- 1) Place the record to be played on the platter.
- 2) Remove the stylus protector cover.
- 3) Set the speed select knob ① to the speed of the record, 33-1/3 r.p.m. record to "33" and 45 r.p.m. record to "45".

Note: When the knob is set at "STOP" position, the motor will not rotate despite of the power being switched on and the neon lamp being lighted up.

- 4) Confirm that the tonearm cueing lever ⑨ is set at "DOWN" position.
- 5) Set the anti-skating knob ⑤ to the same number as shown on the tracking force dial, which is, according to the instruction of your cartridge mounted on the headshell, the optimum value. For example, when the tracking force dial shows "2", the anti-skating knob shall be set at "2".
- 6) Decide how many times you want to listen to the record repeatedly, and set the repeat knob ⑥ to the number of repetition you selected.

* This repeat knob is set only for more than two repetition.

* This repeat knob moves automatically to "1" from "0" when you pull the start-and-reject lever ⑧ to the arrow of "START" for 'non-repetition play'.

* When you set the knob to "R", the record will be played infinitely repeated.

Note: When the dial of the repeat knob indicate other numbers (1,2,3,4,5,6,R) than "0", the platter always rotates and the power will not be turned off.

When you want to stop the automatic play and to turn off the power, set the repeat dial knob to "0" and push the start-and-reject lever ⑧ to the arrow of "REJECT" gently and release it. The lever returns to its original position, the tonearm returns to its rest and the platter quietly stops rotating.

Pay attention not to pull the lever to the arrow of "START", which will cause the record to play once more.

Also, even though the speed select knob ① is set at the "STOP" position during the record play or the tonearm operation, the power will not be turned off though the platter stops rotating.

When the power is switched off, the neon lamp is lighted off.

- 7) Re-confirm the arm cueing lever ⑨ at "DOWN" position.
- 8) After operation from 1) through 7), pull the start-and-reject lever ⑧ gently toward the arrow of "START". Then, the tonearm moves automatically to the first groove of the record of which size has been pre-selected and gently lowers itself to the record surface and play the record repeatedly as often as the pre-setting of the repetition knob.

- 9) The fine pitch adjustment of the platter rotation speed can be made by turning the fine pitch control knob to "F" (standing for 'fast') or to "S" (standing for 'slow') direction. The speed can be checked by the stroboscopic pattern on the rim of the platter (33-1/3 r.p.m.) or the attached stroboscopic pattern plate (45 r.p.m.) which appears to flow from the right to the left, from the left to the right, or to be standing still. When the pattern appears standing still, the speed is correctly adjusted.

When you want to stop playing the record

Set the "0" of the dial of the repeat knob ⑥ to the index, then push the start-and-reject lever ⑧ to the arrow of "REJECT" and release it. The lever returns to its original position and the tonearm returns to its rest to stop the platter rotating.

2. Manual play

- 1) Same as 1) in the "Automatic play."
- 2) Same as 2) in the "Automatic play."
- 3) Same as 3) in the "Automatic play."
- 4) Confirm the tonearm cueing lever ⑨ being set at "UP" position.
- 5) Same as 5) in the "Automatic play."
- 6) Set "0" on the dial of the repeat knob ⑥ to the index.
- 7) Move the tonearm from its rest to the first groove of the record.
- 8) Pull the tonearm cueing lever ⑨ to the arrow of "DOWN" and the tonearm lowers itself slowly on to the record surface.
- 9) After the tonearm completes tracing the record, it lifts up, returns to its rest and the platter stops rotating automatically.

Note: A few records with larger diameters of the innermost groove will not make the automatic mechanism to engage after complete tracing of the record grooves. In this case, move the tonearm slightly to the center of the record and the mechanism will be engaged as described in 9).

When the tonearm cueing lever is set at "DOWN" position, you may play the record if you move the tonearm to any place of the record and gently lower it onto the record surface. Pay attention not to scratch the record grooves with the stylus tip.

When you want to stop playing the record

Push the start-and reject lever ⑧ gently to the direction of the arrow "REJECT" and release it.

CARTRIDGE MOUNTING

Connect the lead wire sockets to the appropriate pins of the cartridge, then fix it to the headshell with the two fixing screws. Keep the fixing screws untightened so that you can undertake the eventual overhang procedures easily.

(The four cartridge lead wires are colour-coded as following.)

Blue (to "LE" or "L-" of the cartridge)

Green (to "RE" or "R-")

Red (to "R+" or "R")

White (to "L+" or "L")

Note: The JL-F45 for U.S. military market has been equipped with 2-channel and 4-channel compatible cartridge (MD-1025) with SHIBATA stylus (4DT-Z1S) improving record groove-to-tip contact while reducing distortion and extending the wear factor of both record and the stylus up to four times than conventional elliptical styli. The cartridge and stylus is optionally available upon request.

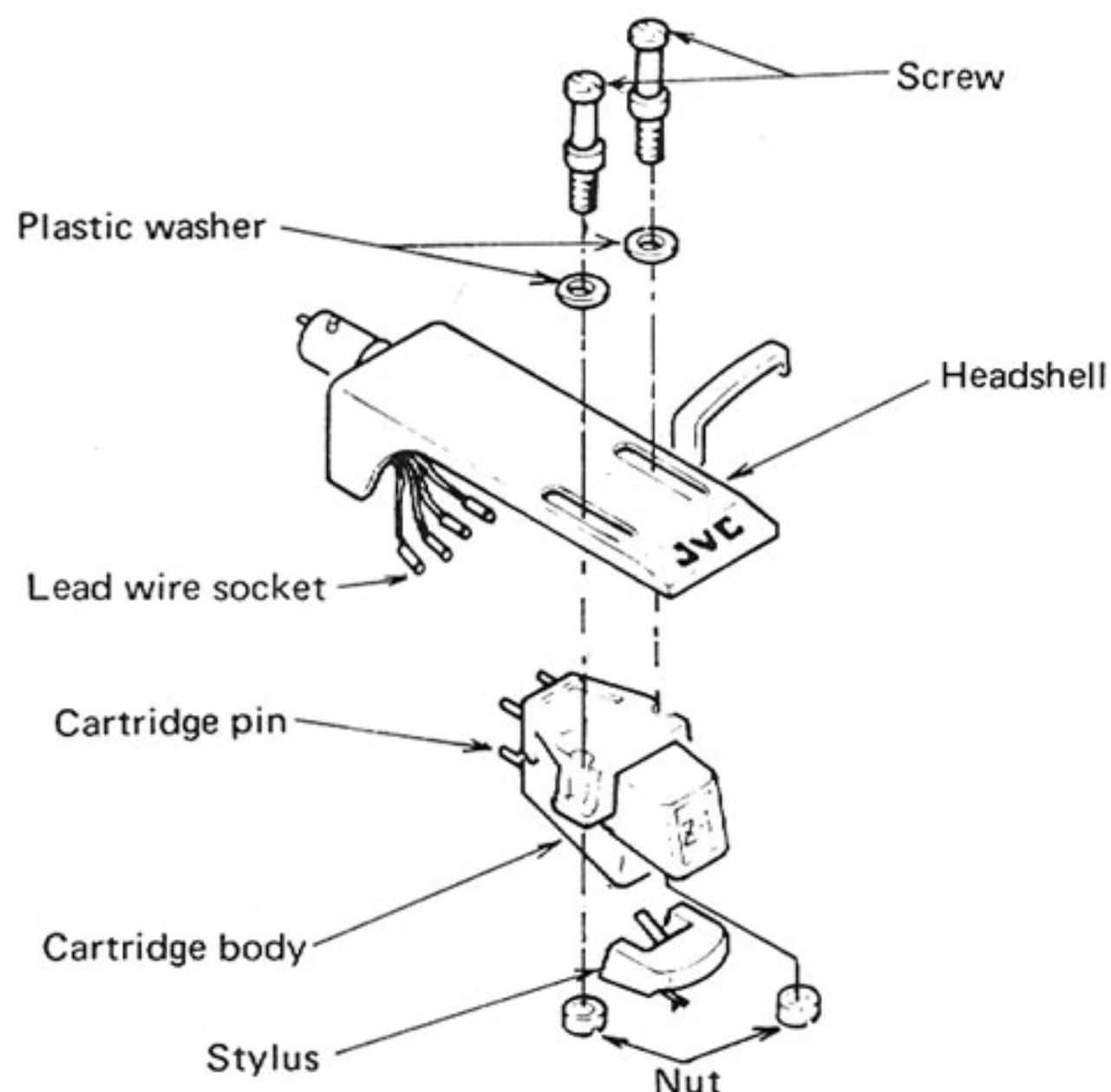

Fig. 18

TROUBLESHOOTING

What seems to be trouble is not always real trouble. Make sure first.

No sound at all

- 1) Are the cables connected properly?
(Cables should be connected firmly and properly.)
- 2) Is the tape monitor switch of the amplifier turned on?
(The tape monitor switch should be turned off.)
- 3) Is the speaker select knob of the amplifier set at "SPEAKER OFF" position?
(The speaker select knob should be set to 1 or 2.)
- 4) Is the source select knob set to other sources than "PHONO"?
(The source select knob should be set to "PHONO" position.)
- 5) Is the volume control of the amplifier set at "MIN"?
(The volume knob should be turned clockwise to a desired level.)
- 6) Is the connector nut of the tonearm loose?
(The connector nut should be firmly tightened.)
- 7) Are cartridge wires coming off or loosely connected?
(The cartridge wires should be firmly connected.)

Noise when playing record

- 1) Is the record worn?
(Replace it with a new one.)
- 2) Is the stylus tip worn?
(Replace it with a new one.)
- 3) Is dust stuck on the stylus tip?
(Clean it with a stylus cleaner.)
- 4) Is the record stuck with dust?
(Clean the record grooves with a record cleaner.)
- 5) Are there low and loud hum?
(Change the power cord path or reverse the AC plug.)

The platter is not running

- 1) Is the power cord coming off from the AC outlet?
- 2) Is the speed select knob set at "STOP" position?
(Select either "33" or "45".)

The stylus is tripping or skating

- 1) Is the tracking force too light?
(Adjust the tracking force.)
- 2) Is the anti-skating knob set properly?
(Refer to "Anti-skating adjustment".)
- 3) Is the record heavily warped?
(Replace it with an unwarped one.)
- 4) Is the turntable installed in a place subject to vibration?
(Select a vibration-free place for installation.)

The loud howling

- 1) Is the turntable near the speakers?
(Put it at least 40cm apart from the speaker.)
- 2) Is the turntable put on the speaker box?
(Move it to a place as far from speakers as possible.)
- 3) Is the volume or bass tone control emphasized to distort the sound?
(Decrease the volume or bass tone control to a level of undistorted sound.)

SPECIFICATIONS

TURNTABLE

Type:	Direct Drive, Fully automatic turntable
Drive Motor:	D.C. Servo Motor
Speeds:	33-1/3 and 45 rpm
Wow and Flutter:	Less than 0.03% (WRMS) 0.05% (DIN)
Signal to noise ratio:	More than 60dB (IEC-B) 70dB (DIN-B)
Pitch control range:	More than $\pm 2.5\%$
Platter:	12-inch (31.1cm) Die-cast aluminum alloy

TONARM

Type:	Statically-balanced S-shaped tubular arm with JVC developed TH (Tracing Holed) balancing system and with tracking force dial of 0.1 gram steps
Effective arm length:	220mm
Overhang:	15mm
Applicable Tracking force range:	0 to 3 grams
Applicable cartridge weight:	14-24 grams (Including Headshell)
Tracking error:	$+3^{\circ}35'$, $-0^{\circ}43'$

GENERAL

Dimensions:	46.0(W) x 36.8(D) x 13.0(H) cm (18-1/8 x 14-1/2 x 5-1/8 inch)
Weight:	11.0kg (24.2 lbs) [9.0kg (19.8 lbs) for U.S.A. and CANADA]
Power supply:	See table 1 at the back cover
Power consumption:	See table 1 at the back cover



POWER SPECIFICATIONS

TABLE 1

Countries	Line Voltage & Frequency	Power Consumption
U.S.A., CANADA	AC 120V, 60Hz	5.6 watts
EUROPE CONTINENT	AC 220V~, 50Hz	5.6 watts
U.K., AUSTRALIA	AC 240V~, 50Hz	5.6 watts
U.S. MILITARY MARKET	AC 110~120V/220~240V Selectable, 50/60Hz	5.6 watts
OTHER AREAS	AC 110~120V/220~240V Selectable, 50/60Hz	5.6 watts